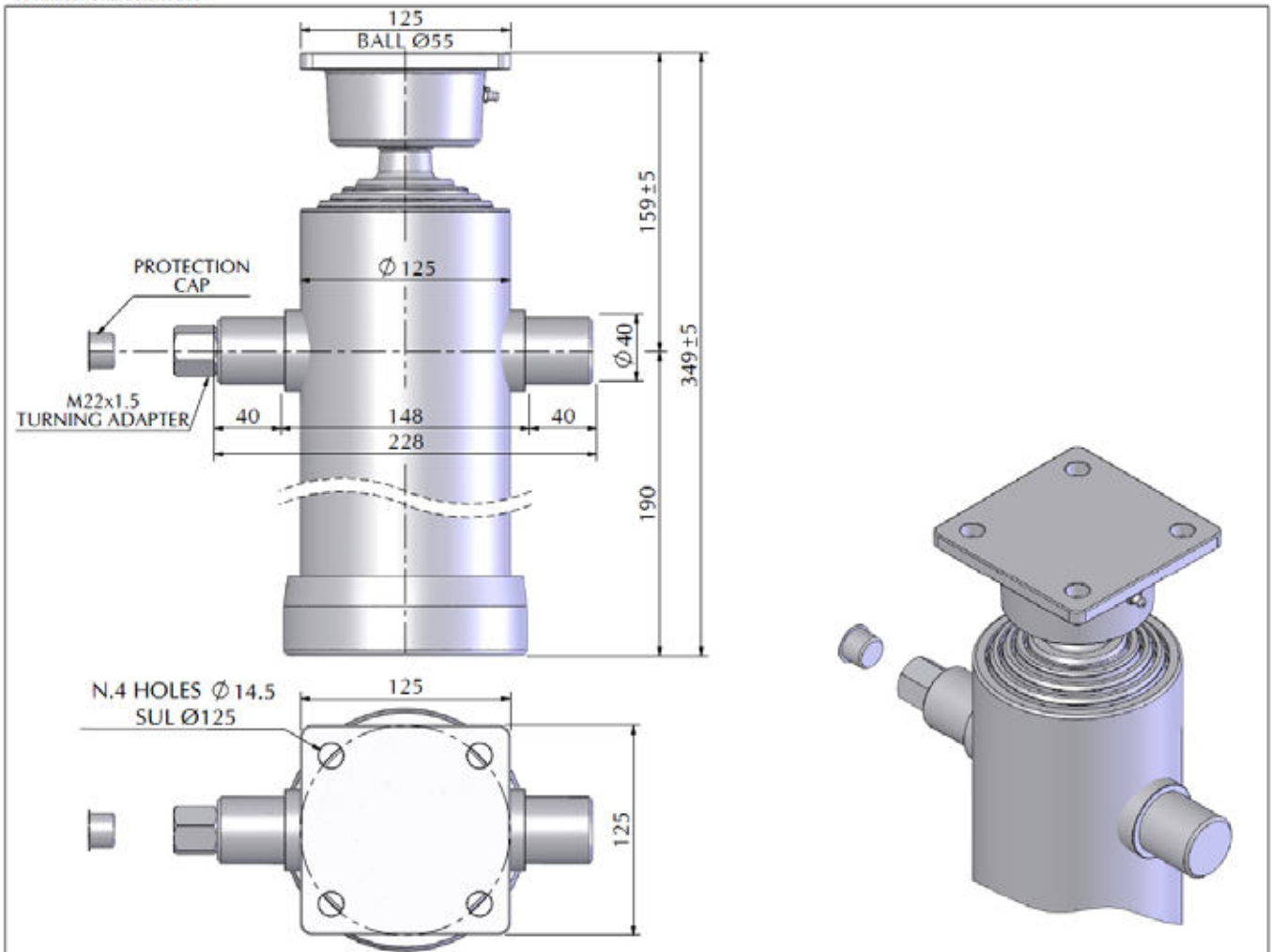

**TELESCOPIC CYLINDER**
**TYPE : BE**
**SERIE : Ø125/4**
**Technical Characteristics**

**Cylinder stages**

Ø Stage	Ø032	Ø045	Ø060	Ø075	Ø090	Ø105	Ø120	Ø140	Ø160						
Thrust at 150 Bar [Tons]	---	---	4.20	6.60	9.50	13.00	---	---	---						
Stages of cylinder			●	●	●	●									

**Specifications**

Stages number	04
Cylinder Stroke [mm]	700
Cylinder weight only [kgs]	22.30
Working volume [Ltrs]	4.40
Max Working pressure [Bar]	200

**Technical Information**

<input type="checkbox"/> Oil	: See oil specification sheet
<input type="checkbox"/> Tipping weight	: Net weight + Payload

**Advices**

All our cylinders are manufactured to suit the particular application in the differing world markets/climate. Should you require details of the exact lifting capacity of the cylinder that has been selected for your application/vehicle then please contact our technical department who will be only pleased to explain or advise.

**Brackets and Accessories**

Closed brackets [ 2 Units per cylinder ]	SC#CSSIN	1.10 [Kgs] x 2=
Open brackets [ 2 Units per cylinder ]	SSA#C	0.80 [Kgs] x 2=
Cradle Type	CU#AB	7.35 [Kgs] x 1=

**Recommendation**

<input type="checkbox"/> This Maritz cylinder is designed as a lifting device only
<input type="checkbox"/> It must not be used as a structural member or be subject to side loads
<input type="checkbox"/> Pump flow in consultation with Maritz engineering department