

**Kreiseleggenzinken (Winkelmesser)**  
**passend für Remac**

L 305 / rechts / Nr. 100/60/15 185506

**Rotary harrow teeth (protractor)**  
**suitable for Remac**

L 305 / rechts / Nr. 100/60/15 185506

Art.Nr.: BODXXX100150

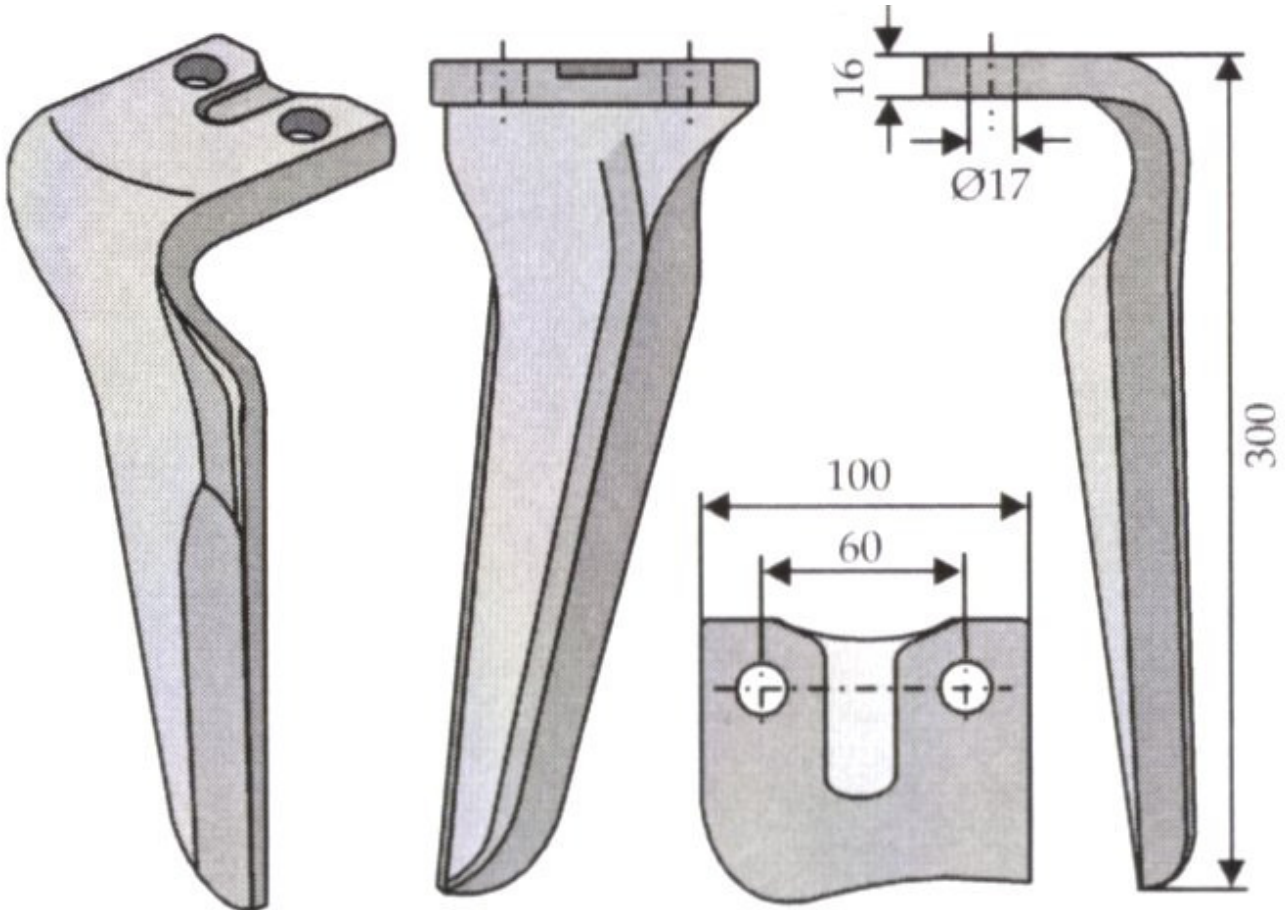

\*Irrtümer, technische Änderungen vorbehalten. | Technical modifications and errors excepted.

Fliegl Agro-Center GmbH · Maierhof 1 · D-84556 Kastl  
Tel. +49 (0)8671/9600-0 · Fax +49 (0)8671/9600-701 · info@agro-center.de

[www.agro-center.de](http://www.agro-center.de)

